

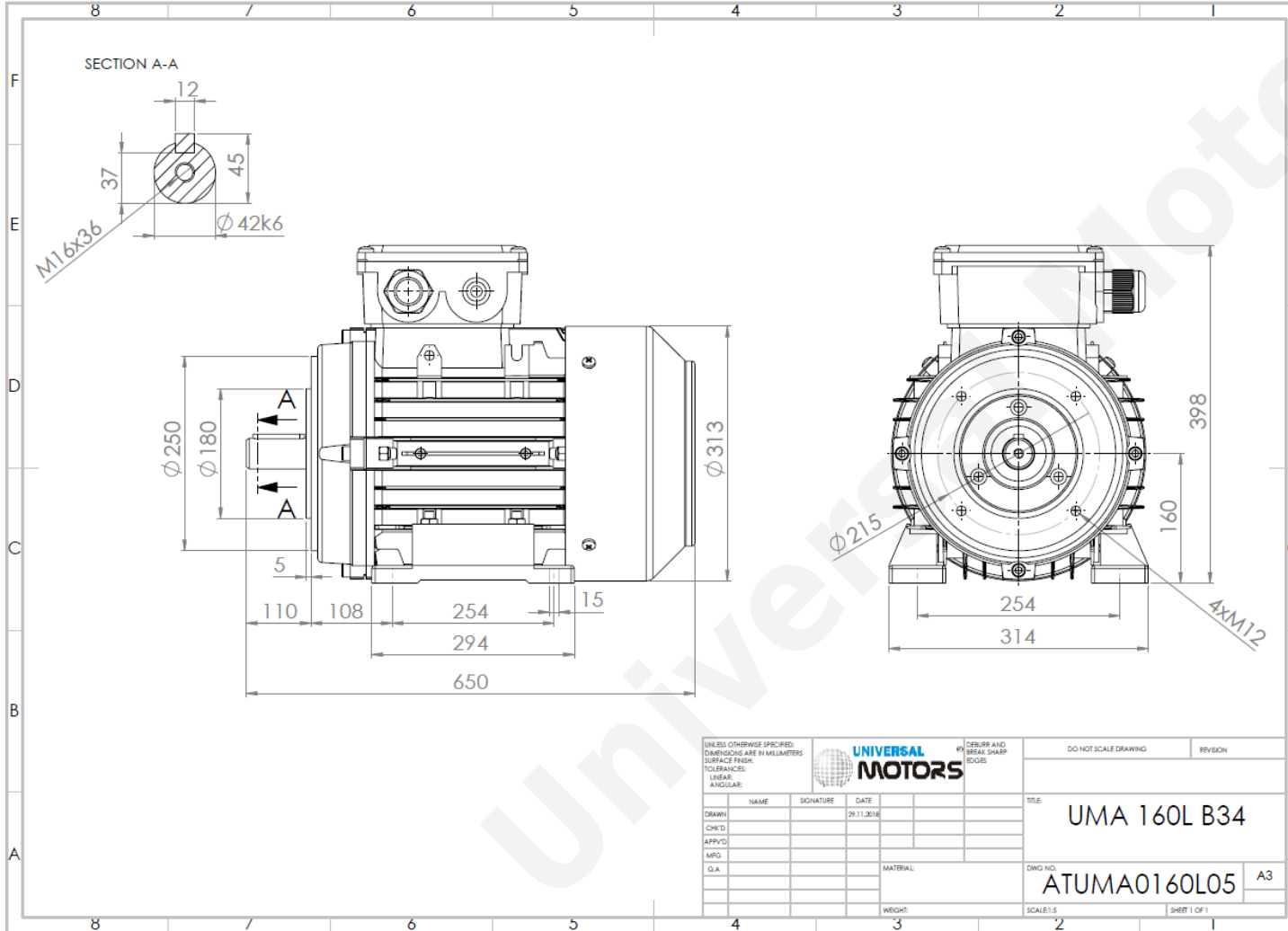

TECHNICAL DATA

Three Phase Electric Motors - Aluminum Frame
 UM3A 160L-2 IE3
 18.5 kW / 25 Cv
 RPM



Motor type:	UM3A 160L-2 IE3
Output:	18.5 kW / 25 Cv
Frequency:	50 Hz
Voltage:	400 V
Current:	31.8 A
Power factor (Cos ϕ):	0.91
Poles:	2
Insulation class:	F
Temperature rise Class:	B
Efficiency 50%:	91.8 %
Efficiency 75%:	92.8 %
Efficiency 100%:	92.4 %
Torque:	60 N.m
Tstarting/Tnominal:	3.0
Istarting/Inominal:	9.1
Tmaximum/Tnominal:	3.0
Noise:	86 Db(A)
Weight:	121 Kg
Brake AC:	AC8
Torque Brake DC:	200 N.m
Bearing DE:	6309 2Z
Bearing NDE:	6
Torque Brake AC:	200 N.m
Brake DC:	K8

Regime - S1

Altitude - 1000m

Environment Temperature - 40°C

CONTACTS:

UNIVERSAL MOTORS Tel: +351 252 299 080
 Rua de São Brás,745 Fax: +351 252 299 089
 4480-782 VILA DO CONDE Mail: geral@universalmotors.pt

* References applied only in the UK